

S2K Flexible Sampling System

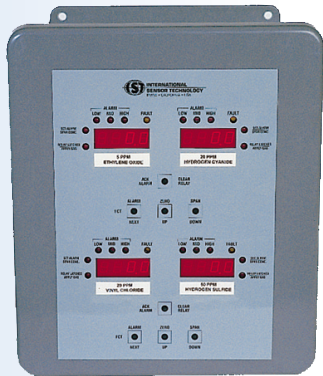

Fig. 2 Three-Timer Cycle

Ext. Pump	Off	On	On
Solenoid Valve	Off	Off	On
	1. External Pump Delay	2. External Pump Lead Time	3. Solenoid Valve Activated
	Cycle Start		Cycle End

- 1** External pump delay: This is the time delay from the beginning of the cycle before the external pump is activated. During this time, the external pump is off. The timer can be set from 0-255 minutes, with a resolution of 1 minute.
- 2** External Pump Lead Time: This is the amount of time the external pump is "ON", before the solenoid valve is switched to let the sample into the sensor chamber. The timer can be set from 0-2550 seconds, with a resolution of 10 seconds.
- 3** This is the amount of time the solenoid valve is activated to allow sample flow into the sensor chamber. The timer can be set from 0-2550 seconds, with a resolution of 10 seconds.

Model S2K Sampling System

The S2K Sampling System offers the following flexible features:

- Basic continuous sampling
- Basic periodic sampling with user adjustable time interval
- Sample dilution to allow sensors to monitor very high gas concentrations
- Timer controlled external bypass pump which improves sampling time, simplifies sample filtration requirements, and reduces pump maintenance.
- Provide viable solution for difficult applications.

Description:

The IST model S2K Sampling System is a flexible sampling system which is designed to condition the sample as required. This system not only brings the sample to the sensor, in many cases, it is the only viable solution to difficult applications. For instance, in applications where the sample concentration is too high for the sensor, the model S2K's ability to dilute samples allows the sensor to be exposed to the sample and provide an accurate reading. Another advantage of non-continuous sampling is the fact that the zero point is confirmed on every reading which increases the confidence level of the measurement. Fig. 1 illustrates phosphine gas diluted at a 5:1 ratio measured on a solid state sensor.

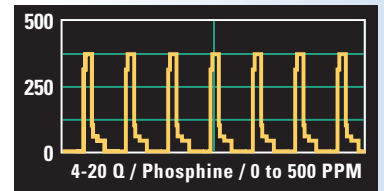

Fig. 1 Phosphine Plot

Functions:

The S2K controls the following functions:

1. A 3-Way solenoid valve: A DIP switch is used to set the amount of time the sample is to be exposed to the sensor. The rest of the time the sensor is exposed to clean air.
2. An external pump control timer which sets the on-off time of the pump. The purpose of the external pump is to transport the sample in larger quantities which shortens the transport time. Additionally, it is easier to draw a controlled amount of sample to be conditioned before exposing it to the sensor. The timer turns the pump on only as needed which prolongs the pump life and reduces pump maintenance.
3. A smaller, internal pump is on constantly to flow either sample or clean air to the sensor.

There are three timers required to implement the complete cycle as shown in Fig. 2.



**INTERNATIONAL
SENSOR TECHNOLOGY**

3 Whatney, Irvine, CA 92618-2824 • Telephone: 949-452-9000 • Fax: 949-452-9009
E-mail: IST@gotgas.com • Website: www.gotgas.com



S2K Flexible Sampling System

Each timer is set by an eight position DIP switch with the following count values:
 $1 + 2 + 4 + 8 + 16 + 32 + 64 + 128 = 255$. This means that position one of the DIP switch has a value of “1” while position 8 has a value of “128”. The time which is set for the timer is calculated by taking the count value and multiplying it by the resolution of the timer. A time of zero is achieved by having all of the switches in the open position.

There is a micro-switch which activates a relay contact if there is a failure of the flow into the sensor chamber. A calibration switch with an LED indicator allows the user to perform standard calibration functions on the sensors. The S2K housing is designed to be used with standard IST 4-20 IQ sensor modules but other sensor modules (such as the SM95) can be used also.

The S2K sampling system can be configured with a variety of options. Fig. 3 illustrates the two-stage sampling system. Figure 4 shows a complete system with a sample diluting assembly. IST will assemble the system to meet application requirements.

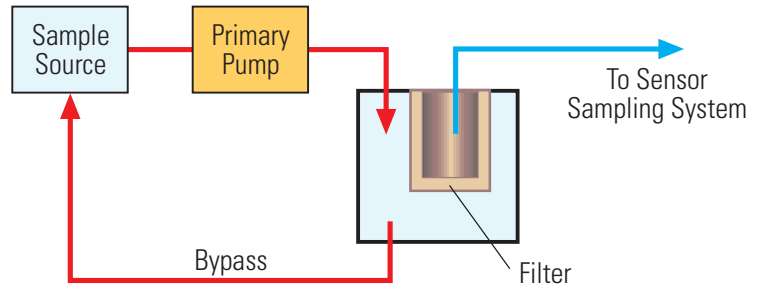

Fig. 3 A Two-Stage Sampling System

System Specifications:

Enclosure: NEMA 4X.

Dimensions: 345(H) x 292(W) x 127(D) mm;
 (13.6"H x 11.5"W x 5.0"D).

Weight: 5.5 Kg (12 Lbs).

Timer controller function: See description above.

Relay: SPST Normally Open, 5 amp resistive.
 220 VAC max. 1/8 HP motor.

Three relays are provided for the following:

1. No flow into sensor chamber.
2. External pump activation Relay.
3. Solenoid valve.

Internal Pump: Oscillating AC Diaphragm. Replaceable.

Flow Meter: Dwyer Instrument, Inc. RMA-13-SSV. Ranges as specified.

Power: 110/220 VAC, 50/60 Hz.

Temperature Range: -20°C to 50°C.

Humidity: Non-condensing.

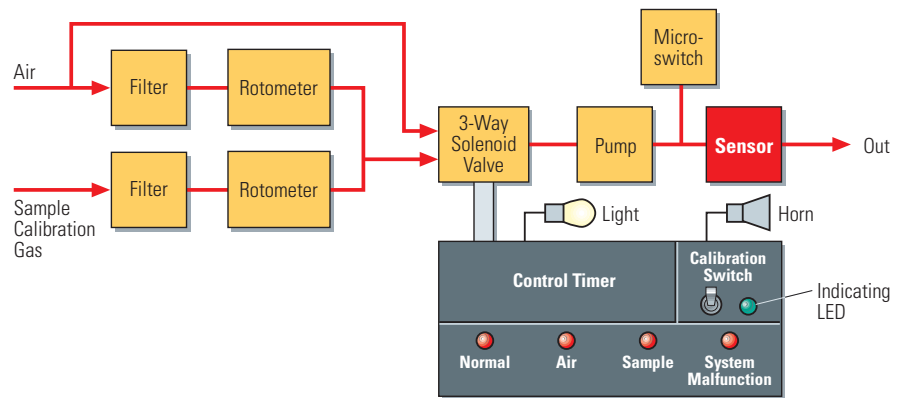

Fig. 4 Sample Dilution and Timer Set Up

Represented by: